

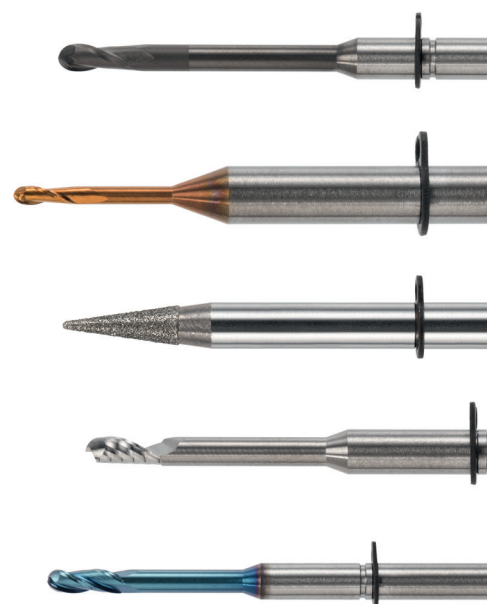

CAD/CAM

made in Germany



Kompatibel mit · Compatible with

VHF FRÄSER

S1 / S2 / K5 / K5+ / R5 / S5
K3 / K4 / K4 edition / Z4 / N4 / N4+
N4 / N4+ / S1 / S2 / Z4 / S5 / R5

S1 / S2 / K5 / K5+ / R5 / S5

ZRO2

AC-KRISTALL



	V5 2R5 Z06	V5 2R5 Z10	V5 2R5 Z20	V5 3R5 Z20
Ø mm	0,6	1,0	2,0	2,0
	Z060 R2D 40	Z100 R2D 40	/	Z200 R3D 40
	2-Schneider 2 blades			3-Schneider 3 blades

ZRO2

AC-KRISTALL



V5 2F5 Z12
1,2
Z120 F2D 40
2-Schneider 2 blades

ZRO2

AC-BLUE

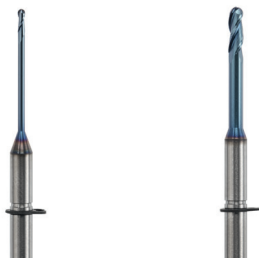

	V5 2R3 Z10	V5 3R3 Z20
Ø mm	1,0	2,0
	Z100 R2 40	Z200 R3 40
	2-Schneider 2 blades	3-Schneider 3 blades

ZRO2



	V5 2R0 Z10	V5 3R0 Z20
Ø mm	1,0	2,0
	/	/
	2-Schneider 2 blades	3-Schneider 3 blades

PMMA, WAX



	V5 2R0 P10	V5 2R0 P20
Ø mm	1,0	2,0
	P100 R2 40	P200 R2 40
	2-Schneider 2 blades	

PMMA



	V5 1R0 P10	V5 1R0 P20	V5 1F0 P25
Ø mm	1,0	2,0	2,5
	P100 R1 40	P200 R1 40	P250 F1 40
	1-Schneider 1 blade		

S1 / S2 / K5 / K5+ / R5 / S5

COMPOSITE

UNIVERSAL



	V5 2R0 P10	V5 2R0 P20
Ø mm	1,0	2,0
	C100 R2 40	C200 R2 40
	2-Schneider 2 blades	



	V5 2R0 U06	V5 2FO U12
Ø mm	0,6	1,2
	U060 R2 40	U120 F2 40
	2-Schneider 2 blades	

COCR, TITAN

AC-FIRE



	V5 2R4 M06	V5 2R4 M10	V5 2R4 M20	V5 4R4 M20
Ø mm	0,6	1,0	2,0	2,0
	M060 R2 35	M100 R2 35	M200 R2 35	M200 R4 35
	2-Schneider 2 blades			4-Schneider 4 blades

DIAMANT SCHLEIFER N4 / N4+ / S1 / S2 / Z4 / S5 / R5

GLASKERAMIK Glass ceramic – galvanic diamond coating

GALVANISCHE DIAMANTBESCHICHTUNG





	806 335 300 091 006	806 335 200 091 010	806 335 200 181 024
Ø mm	0,6	1,0	2,4
	G060 R 35	G100 R 35	G240 R 35
	Radiusschleifstift Grinding Tool		

K3 / K4 / K4 EDITION / Z4 / N4 / N4+

ZR02

AC-BLUE



	V4 2R0 U06	V4 2R0 U10	V4 3R0 Z20	V4 2R3 Z10	V4 3R3 Z20
Ø mm	0,6	1,0	2,0	1,0	2,0
	Z060 R2D 35	/	/	Z100 R2 35	Z200 R3 35
	2-Schneider 2 blades		3-Schneider 3 blades	2-Schneider 2 blades	3-Schneider 3 blades

K3 / K4 / K4 EDITION / Z4 / N4 / N4+

PMMA, WAX

PMMA

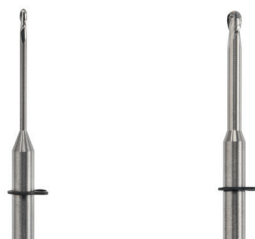

	V4 2R0 U10	V4 2R0 P20
Ø mm	1,0	2,0
	P100 R2 35	P200 R2 35
	2-Schneider 2 blades	



	V4 1R0 P10	V4 1R0 P20
Ø mm	1,0	2,0
	P100 R1 35	P200 R1 35
	1-Schneider 1 blade	

COMPOSITE

UNIVERSAL

COCR, TITAN

AC-FIRE



	V4 2R0 U10	V4 2R0 P20	V4 2R0 U06
Ø mm	1,0	2,0	0,6
	C100 R2 35	C200 R2 35	U060 R2 35
	2-Schneider 2 blades		

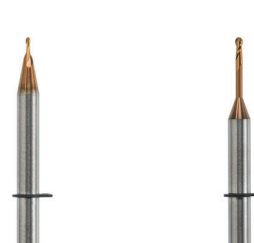

	V4 2R4 M06	V4 2R4 M10
Ø mm	0,6	1,0
	M060 R2 32	M100 R2 32
	2-Schneider 2 blades	

VERSCHLEISS-SCHUTZSCHICHTEN

wear-protection coating



AC-BLUE

Universelle, sehr harte und glatte PVD/Verschleißschutzschicht
Schichtstärke: ca. $3,0\ \mu\text{m}$, Schichtarchitektur: nano Composite
Basis: Supernitrid ALTiN + SN, Schichtfarbe: blau, glänzend
Härte, HV 0,05: 3.700, Schicht ist elektrisch leitend,
Max. Einsatz/Temperatur: $1.100\ ^\circ\text{C}$, Reibungskoeffizient
gegen Stahl 0,2. Besonders geeignet für Trockenbearbeitung
Für alle fräsbaren Materialien, Kunststoffe, Composite, Metall
und Standard Zirkonoxid

AC-BLUE

Hard and smooth PVD/ wear protection coating, coating thick-
ness: approx. $1,5\ \mu\text{m}$, Coating architecture: nano-composite,
basis: supernitride ALTiN + SN, Coating colour: blue, brilliant,
hardness, HV 0,05: 3.700, The coating is electrically conductive,
max. use/ temperature: $1.100\ ^\circ\text{C}$, Coefficient of friction against
steel 0,2, particularly suitable for dry machining
For all millable materials, synthetic material, composite, metal
and standard zirconium oxide



AC-FIRE

PVD Schicht nach dem HiPIMS-Verfahren, speziell für die Hart-
stoffzerspanung, Schichtstärke: $1,5\text{--}2,5\ \mu\text{m}$, Schichtarchitektur:
Nano Composite, Basis TiAlN + Si, Schichtfarbe: kupferfarben,
glänzend, Härte HV 0,05: 3.800, elektrisch leitend, max. Einsatz-
temperatur: $1.100\ ^\circ\text{C}$, Reibwert gg. Stahl 0,3; besonders geeignet
für schwer zu zerspanende Legierungen – CoCr und Titan

AC-FIRE

PVD-coating on the basis of the HiPIMS-procedure, especially for
the chipping of hard materials, coating thickness: approx. $1,0\ \mu\text{m}$,
coating architecture: Nano composite, Basis: TiAlN + Si,
Coating colour: copper, shiny, Hardness HV 0,05 : 3.800,
electrically conductive, max. operating temperature: $1.000\ ^\circ\text{C}$,
coefficient of friction against steel 0,3; particularly suitable
for materials which are hard to machine – CrCo and Titanium



AC-KRISTALL (DIAMANTBESCHICHTUNG)

CVD-Spezialschicht zum Bearbeiten hoch abrasiver Materialien
(z.B. ZrO), Schichtstärke: ca. $6\ \mu\text{m}$, Schichtarchitektur: nano-krist-
talline Schicht, Basis: Kristalline C-Schicht, Farbe: grau/schwarz,
Härte: HV 0,05: 10.000, Schicht nicht elektrisch leitend,
max. Einsatztemperatur: $600\text{--}700\ ^\circ\text{C}$, Standwegehöpfung
bis zu 10-fach, hohe Wärmeleitfähigkeit

AC-CRYSTAL (DIAMOND COATING)

CVD-special coating for the treatment of highly abrasive materials
(e.g. ZrO), Coating thickness: approx. $6\ \mu\text{m}$, coating architecture:
nano-crystalline coating, Colour: grey/ black, hardness HV 0,05:
10.000, The coating is not electrically conductive, max. operation
temperature: $600\text{--}700\ ^\circ\text{C}$, Increased tool life up to factor 10,
high thermal conductivity

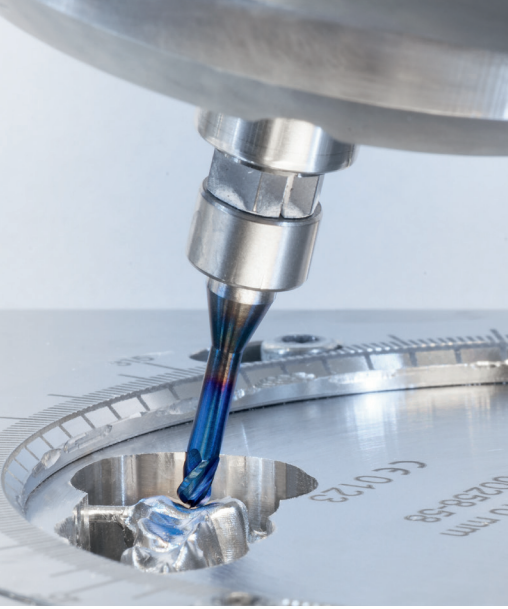

ROTIERENDE HOCHLEISTUNGSINSTRUMENTE

auf höchstem Niveau.

Zahnmediziner, Dentallabore und Podologen wertschätzen unsere praxisorientierten, bedarfsgerechten Produkte mittlerweile weltweit. Denn wir hören zu und hinterfragen. Auf einer Augenhöhe mit unseren Kunden. Auf diese Weise stellen hochkonzentrierte, leidenschaftliche Perfektionisten bei acurata absolut verlässliche Präzisionsinstrumente her, die ein ultragenau arbeiten in Labor und Praxis erst ermöglichen. Zuverlässigkeit im sensiblen Zusammenwirken aller Kräfte – technisch und menschlich.

HIGH PERFORMANCE DENTAL INSTRUMENTS

to the highest technological level.

Dentists and dental laboratories now value our practically-oriented, needs-oriented products all over the world. We also listen and ask questions - at the same level as our customers. It is in this context that the highly focused, dedicated perfectionists at acurata manufacture absolutely reliable precision instruments which enable ultra-accurate work in the laboratory and in the dental practice. Reliability in the context of a sensitive collaboration between all of our talents – at the technical and human level.

WWW.ACURATA.DE



📍 acurata GmbH & Co. KGaA · Schulstraße 25 · 94169 Thurmansbang 📞 Telefon +49 8504 9117-0 📠 Fax +49 8504 9117-90

© 2023 acurata GmbH & Co. KGaA, Thurmansbang · Alle Rechte vorbehalten · All rights reserved · acurata CAD/CAM Flyer VHF 2023/08

acurata